

## Vector Part No.: " CG2-50P "

" Plastic Screw-in Card Guides { 4.39" L, 3.75" Ctrs, 5.00" Card Length } for EIA Subracks and VectorPak System "

Part No.	Type	Length	Centers	Card Length	Application
<a href="#">CG2-45P</a>	Plastic, Screw-in	2.89"	2.25"	4.50"	 <p style="text-align: center;">Snap-in Nylon Card Guide Top &amp; Side View</p> <p style="text-align: center;">Screw-in Plastic card Guide</p> <p style="text-align: center;">Screw-in Metal Card Guide</p>
<a href="#">CG2-45S</a>	Nylon, Snap-in	3.17"	2.25"	4.50"	
<a href="#">CG2-50P</a>	Plastic, Screw-in	4.39"	3.75"	5.00"	
<a href="#">CG2-65M</a>	Metal, Screw-in	5.42"	4.50"	6.50"	
<a href="#">CG2-65P</a>	Plastic, Screw-in	5.42"	4.50"	6.50"	
<a href="#">CG2-65S</a>	Nylon, Snap-in	5.42"	4.50"	6.50"	
<a href="#">CG2-80P</a>	Plastic, Screw-in	6.64"	6.00"	8.00"	
<a href="#">CG2-80S</a>	Nylon, Snap-in	6.93"	7.50"	8.00"	
<a href="#">CG2-95M</a>	Metal, Screw-in	8.14"	7.50"	9.50"	
<a href="#">CG2-95P</a>	Plastic, Screw-in	8.14"	7.50"	9.50"	
<a href="#">CG2-95S</a>	Nylon, Snap-in	8.43"	7.50"	9.50"	

### Dimensions and Drawing Examples

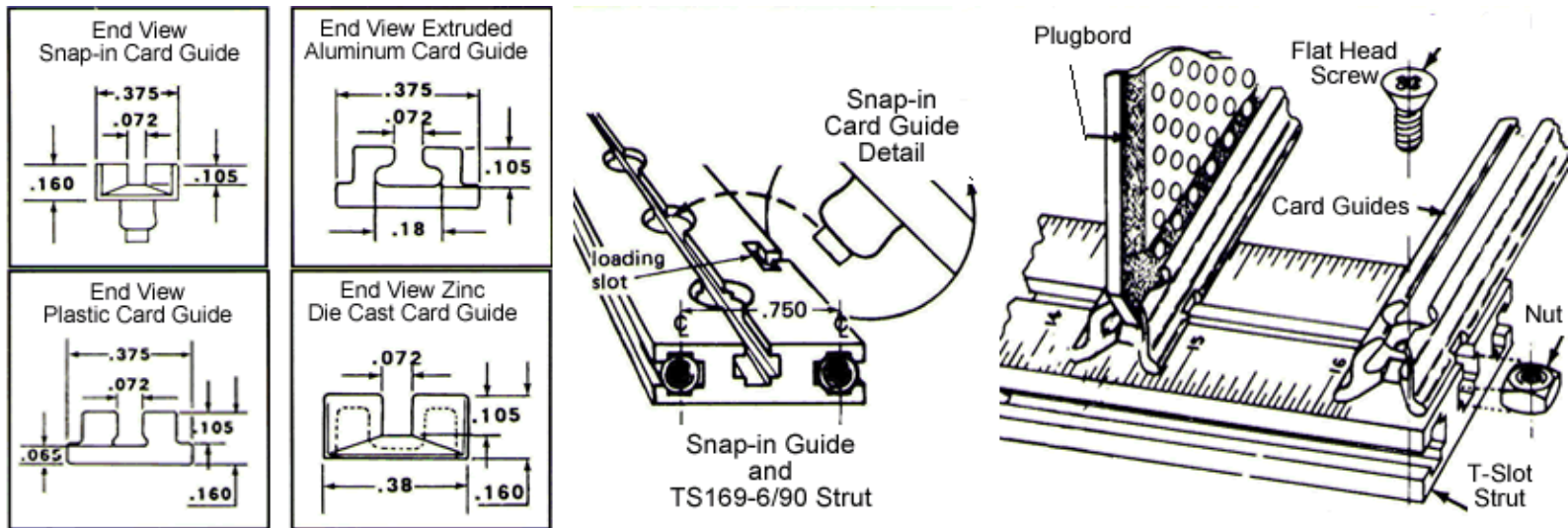

### Description

High quality Snap-in card guides feature tapered slots for easy insertion and removal without tools. Snap-in card guide can be positioned at **0.25"** increments when used with Vector-Pak T-struts ( **TS169-6/90** ). Holes for mounting guides to struts are based on center-to-center multiples of **0.75"**. Screw mounted models are available in metal or plastic { installation hardware included } Screw mounted metal or plastic card guides provide variable positioning along entire length of strut. Metal or plastic screw down card guides attach with **SC4-27/25** flat head screw and **NT4-7PA** square nut as shown in drawing. All materials are flame retardant.